

## DY1150 Features:

- \*Compact design, Easy to handle.
- \*Small turning radius.
- \*Telescopic Boom as standard.
- \*Self Levelling.
- \*Anti-slip valve.
- \*Boom Float function.
- \*Optional Rear Hydraulic Output.
- \*Convenient to maintain.
- \*Great maneuverability – works in tight situations
- \*Sound alarm for maintenance and warnings.
- \*High-flow auxiliary hydraulics runs almost any attachment.
- \*CE, FOPS & ROPS Certified.

## Main Components

- \*Engine: Perkins / Yanmar / Kohler
- \*Hydraulic Pump: **PWG**
- \*Hydraulic Valve: Bucher



## DY1150 Specifications

<b>Dimension (LxWxH)</b>	<b>3410mm*1500mm*2350mm</b>
<b>Max.Reach(Boom Extended)</b>	<b>3540mm</b>
<b>Max. Reach(Boom Retracted)</b>	<b>2910mm</b>
<b>Bucket Capacity</b>	<b>600L</b>
<b>Rated Loading Capacity</b>	<b>1600kg</b>
<b>Tipping Load</b>	<b>2600kg</b>
<b>Min. Turning Radius</b>	<b>2818mm</b>
<b>Ground Clearance</b>	<b>330mm</b>
<b>Turning Angle</b>	<b>43 Degree</b>
<b>Speed</b>	<b>16.5km/h</b>
<b>Weight</b>	<b>2300kg</b>
<b>Standard Tires</b>	<b>31X15.5-15</b>

<b>Tire Pressure</b>	<b>2.8Bar</b>
<b>Oil Tank Capacity</b>	<b>70L</b>
<b>Fuel tank capacity</b>	<b>32L</b>
<b>Pressure</b>	<b>200bar</b>
<b>Working Oil Flow</b>	<b>82L/min</b>
<b>Tracking Oil Flow</b>	<b>117L/min</b>
<b>Oil Model(Mineral Oil)</b>	<b>L-HL46</b>
<b>Battery Capacity</b>	<b>70Ah</b>
<b>Voltage</b>	<b>12V</b>
<b>Angle of departure</b>	<b>20°</b>

## DY1150 Dimensions

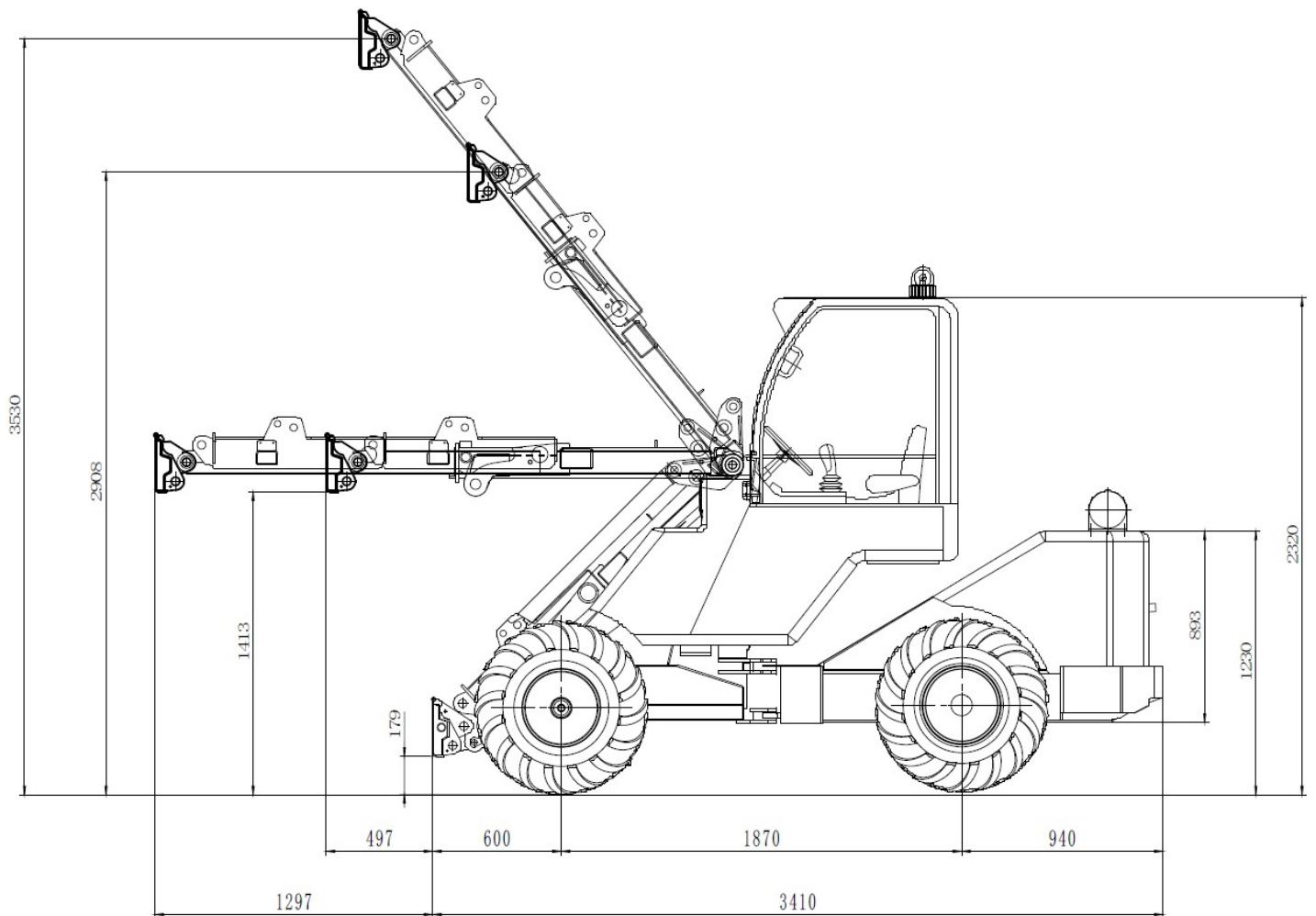

**Yanmar 4TNV94L**

**KOHLER KDI1903TCR**

**EURO III**

**EPA Tier 4/Euro 3B**

Water Cooling

Water Cooling

4 Cylinders

3 Cylinders

35.5KW (48HP)

41KW (56HP)

2400r/min

2200 r/min

high pressure common rail, turbocharger

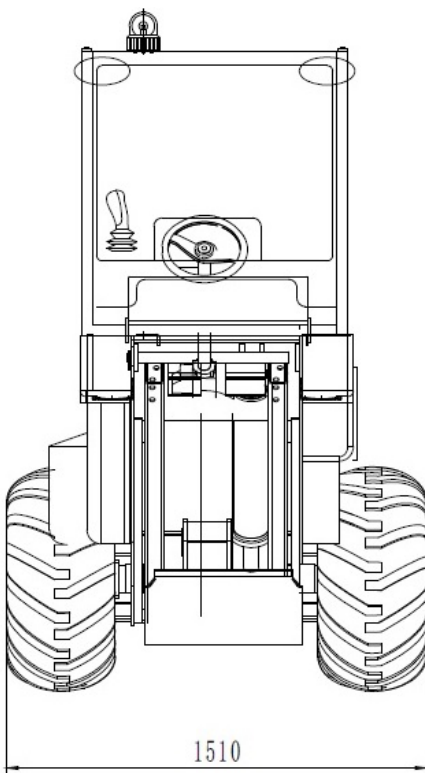

**D**

